

5022-S SPRING APPLIED BRAKE CALIPER

Spring applied calipers are used in applications where the spring keeps the brake applied and fluid pressure releases the brake. These brakes lend themselves extremely well for long term parking brakes. It is not possible to store fluid pressure for a long period of time. However, spring tension can be maintained almost indefinitely.

The actuators are very responsive to control pressure and the brakes can be infinitely controlled. The slightest change in fluid pressure will cause a proportional change in brake force. The balancing links provided on all Kobelt brake calipers keep the spring applied actuators in the mid position and ensure equal brake lining wear on both shoes. If the balancing links are removed it will allow the brake actuator to float and compensate for a disc which is attached to a rotating element that is also floating.

Specifications

Clamping force	18240 lbs.	(8272 kg.)
Max. disc thickness	2.00 in.	(51 mm)
Req. disc face	4 in.	(102 mm)
Total lining area	86 sq. in.	(555 sq. cm)
Lining thickness	0.5 in.	(12.7 mm)
Max. allowable lining wear	0.30 in.	(7.6 mm)
Average wear rate	0.005 cu. in./HP-hr	(0.082 cu. cm/HP-hr)
Coefficient of friction	0.45 at 68°F	(20°C)
Coefficient of friction	0.55 at 500°F	(260°C)
Max. release pressure	120 psi	(8.3 bar)
Max. pressure	250 psi	(17 bar)
Actuator volume	38 cu. in.	(673 cu. cm)
Weight	102 lb.	(46 kg)
Materials	Die cast silicon bronze with stainless steel hardware and rolled steel tie rods	

Important: Use only hydraulic fluid or air. Standard seals are not compatible with brake fluid.

Ordering Information

5022-S	Spring Applied Brake Caliper
5022-SR	Spring Applied Brake Caliper with manual release screw

When ordering brake calipers for discs smaller than the standard thickness, shim kits are available for adjustment. Add the last four digits of the appropriate kit to the code when ordering.

Example: 5022-S1250 is for a 5022-S brake caliper set for 1¼" thick disc.

STANDARD VENTILATED KOBELT DISC: 2.00 in. (51mm)

Disc Dia.	18	20	25	30	35	40	45	50
inches	18	20	25	30	35	40	45	50
mm	457	508	635	762	889	1016	1143	1270
Acting Rad.								
ft	.583	.666	.875	1.083	1.292	1.500	1.708	1.917
meter	.178	.203	.267	.330	.394	.457	.521	.584
Torque								
ft-lb	5320	6080	7980	9880	11780	13680	15580	17480
kg-m	736	840	1104	1364	1628	1890	2154	2416
Maximum RPM	3070	2750	2200	1800	1550	1350	1200	1070

A variety of custom made disc are available. For discs smaller than the standard thickness, refer to the shim kit table below.

Disc thickness	Shim Kit Part number	Total shim size
1.50 in. (38.1 mm)	5022-1500	0.50 in (12.7 mm) 1 shim (1/4") per side
1.25 in. (31.8 mm)	5022-1250	0.75 in (19 mm) 1 shim (3/8") per side
1.00 in. (25.4 mm)	5022-1000	1.00 in. (25.4 mm) 2 shims (1/4") per side
0.75 in. (19 mm)	5022-0750	1.25 in. (31.8 mm) 2 shims (3/8"+1/4") per side
0.50 in. (12.7 mm)	5022-0500	1.50 in. (38.1 mm) 2 shims (3/8") per side

MODEL 5022-S

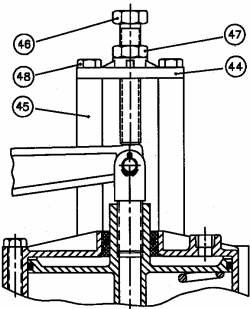
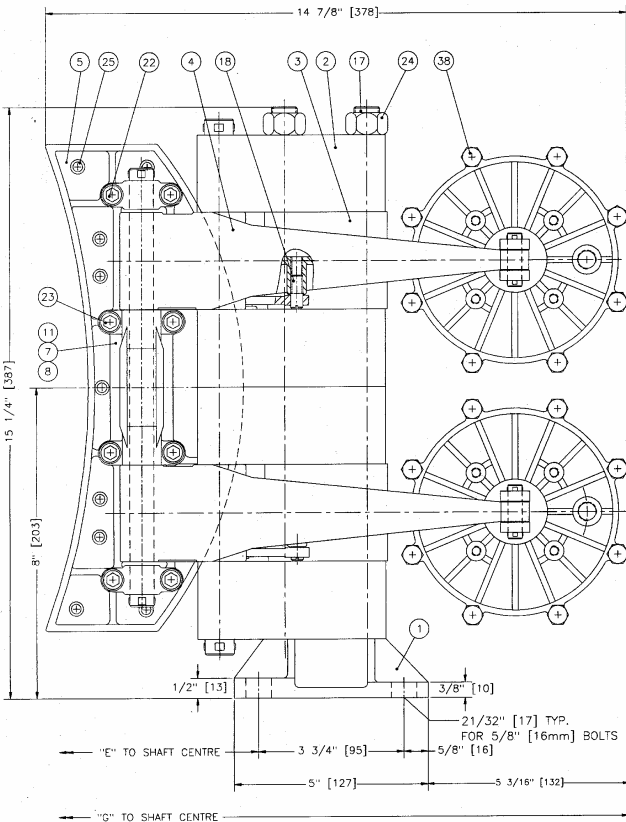
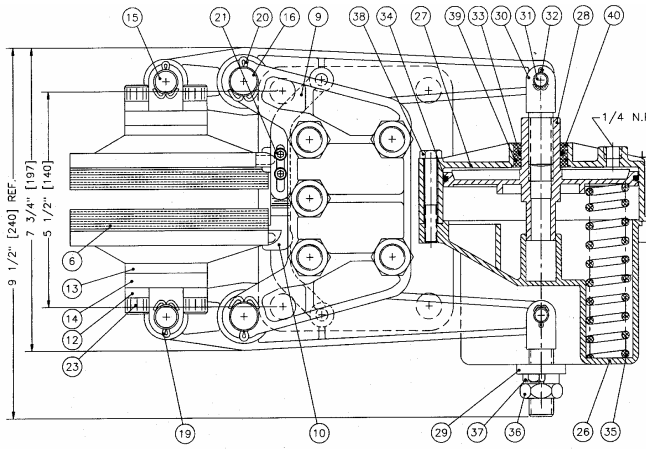

MANUAL RELEASE OPTION

CAUTION:
When dismantling the actuator, it is important that it is retained in a press before removing the assembly screws.

Disc diameter	18	20	25	30	35	40	45	50
inches	18	20	25	30	35	40	45	50
mm	457	508	635	762	889	1016	1143	1270
Dimension "E"								
inches	9.37	10.37	12.87	15.37	17.87	20.37	22.87	25.37
mm	238	263	327	390	454	517	581	644
Dimension "G"								
inches	19.12	20.12	22.62	25.12	27.62	30.12	32.62	35.12
mm	486	511	575	638	702	765	829	892

Item	Qty	Part No.	Description
1	1	5021-0001	Foot
2	4	5021-0002	Saddle
3	2	5021-0003	Spacer
4	4	5021-0004	Lever
5	2	5022-0005	Shoe
6	2	5022-0007	Lining
7	*	5021-0008	1/4" Shim (centre bearing)
8	*	5021-0009	3/8" Shim (centre bearing)
9	2	5021-0011	Balancing Link No. 1
10	2	5021-0012	Balancing Link No. 2
11	2	5022-0013	Centre Bearing
12	4	5022-0014	Outside Bearing
13	*	5022-0015	1/4" Shim (outside bearing)
14	*	5022-0016	3/8" Shim (outside bearing)
15	2	5022-0021	Shoe Pin
16	2	5022-0022	Saddle Pin
17	5	5022-0023	Tie Rod
18	2	5021-0226	Link Pin
19	4	1026-0516	Cotter Pin
20	4	1026-0824	Cotter Pin
21	4	1002-0808	Socket Hd Screw
22	8	1002-1112	Socket Hd Screw (standard)
22	*	1002-1116	Socket Hd. Cap Screw (5022-1500 shim kit)
22	*	1002-1120	Socket Hd. Cap Screw (5022-1250/1000 shim kit)
22	*	1002-1124	Socket Hd. Cap Screw (5022-0750/0500 shim kit)
23	8	1002-1216	Socket Hd Screw (standard)
23	*	1002-1220	Socket Hd. Cap Screw (5022-1500 shim kit)
23	*	1002-1224	Socket Hd. Cap Screw (5022-1250/1000 shim kit)
23	*	1002-1228	Socket Hd. Cap Screw (5022-0750/0500 shim kit)
24	5	1002-0116	Nut
25	38	1033-1007	Rivet
6212 Spring Applied Pot			
26	2	6212-0001	Spring Housing
27	2	6212-0002	Piston Housing
28	2	6212-0003	Piston
29	2	6212-0004	Bracket
30	4	6212-0005	Clevis
31	4	6112-0010-L	Pin
32	8	1026-0312	Cotter Pin
33	2	1101-0214	"O" Ring
34	2	1101-0248	"O" Ring
35	16	1201-0035	Spring
36	2	1022-0216	Jam Nut
37	4	1001-1112	Hex Hd Bolt
38	16	1001-1136	Hex Hd Bolt
39	2	1101-0026	"O" Ring
40	2	6212-PHB	Bushing
Manual Release Option			
44	2	6212-0006	Manual Release Bracket
45	8	6212-0007	Spacer
46	2	1001-1448	Release Screw
47	2	1022-0214	Jam Nut
48	8	1001-1156	Hex Hd. Bolt

* Quantity may vary with options